

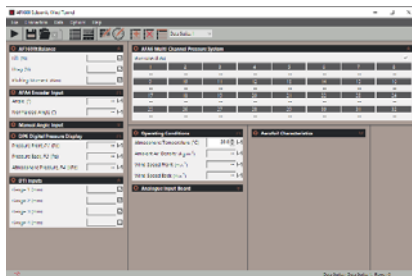

≡ SUBSONIC WIND TUNNEL 600 MM

VDAS® AF1600S

TecQuipment's largest open-circuit subsonic wind tunnel, with a working section of 600 mm by 600 mm and 1250 mm long, is for the study of advanced aerodynamics theory and research. With the larger size comes greater visualisation and more accurate results, operating at meaningful Reynolds numbers.



SCREENSHOT OF THE VDAS® SOFTWARE

KEY FEATURES

- A cost-effective solution when compared to full-scale wind tunnels or airborne laboratories
- Operates at meaningful Reynolds numbers
- Safe, open-circuit suction design
- Package includes three-component balance, angle feedback unit, dual differential pressure display, 32-way pressure display unit, Pitot static traverse, X/Y Pitot static traverse, protractor, model holder and data acquisition (VDAS-F)
- High levels of safety
- Controls and instrumentation conveniently mount on a separate, free-standing frame



≡ SUBSONIC WIND TUNNEL 600 MM

VDAS® AF1600S

DESCRIPTION

Air passes into the AF1600 through a honeycomb flow straightener and a grille. It then passes into an aerodynamically designed effuser (cone) that accelerates the air in a linear manner before it moves through the working section. Finally it passes through a diffuser, then into the variable speed axial fan. The grille protects the fan from damage by loose objects. The air leaves the fan, passes through a silencer unit and then back out to atmosphere.

The speed of the axial fan (and therefore the air velocity in the working section) is controlled by an electronic drive control in the separate On/Off unit mounted on the tunnel's associated instrument frame along with other ancillaries.

WORKING SECTION

The working section is of a square section with tapered chamfered corners and an acrylic roof and floor. The sides are full length acrylic panels, one side is hinged at the top and the other is removable. The whole unit is supported in an aluminium framework. Each side panel has a holder to support wind tunnel models. On the top of the working section are two Pitot devices and a wall tapping to measure the static pressure upstream and downstream of the working section.

INCLUDED WITH THE WIND TUNNEL

THREE-COMPONENT BALANCE (AF1600T)

Measures lift, drag and pitching moment of models in the wind tunnel.

BALANCE ANGLE FEEDBACK UNIT (AFA4)

(Included with AF1600T). Measures the angular position of models mounted on the balance in the wind tunnel.

DUAL DIFFERENTIAL PRESSURE DISPLAY (DP6)

Measures and displays pressures with respect to the atmosphere or differential pressures.

32-WAY PRESSURE DISPLAY UNIT (AFA6)

Measures and displays up to 32 different pressures from models' Pitot-static tubes and other measuring instruments fitted to the wind tunnel.

PITOT-STATIC TRAVERSE (AFA7)

A traversing Pitot static tube with electronic position measurement.

PITOT-STATIC X/Y TRAVERSE (AF1600XY)

A traversing (X and Y plane) Pitot static tube with electronic position measurement.

PROTRACTOR

For assisting with setting up models and rotating them during experiments.

MODEL HOLDER

To hold models when the three component balance is not used. Also to hold users own models.

VERSATILE DATA ACQUISITION SYSTEM (VDAS-F)

A frame-mounting versatile data acquisition system (VDAS®) to allow computer-based data capture.

CYLINDER MODEL WITH PRESSURE TAPPING (AF1600A)

A cylinder model with a pressure tapping that spans the full width of the working section.

OPTIONAL EXTRAS INCLUDE

MULTI-TUBE MANOMETER (AFAI)

A tilting 36-tube manometer

SMOKE GENERATOR (AFA11)

To assist with visualising air flow

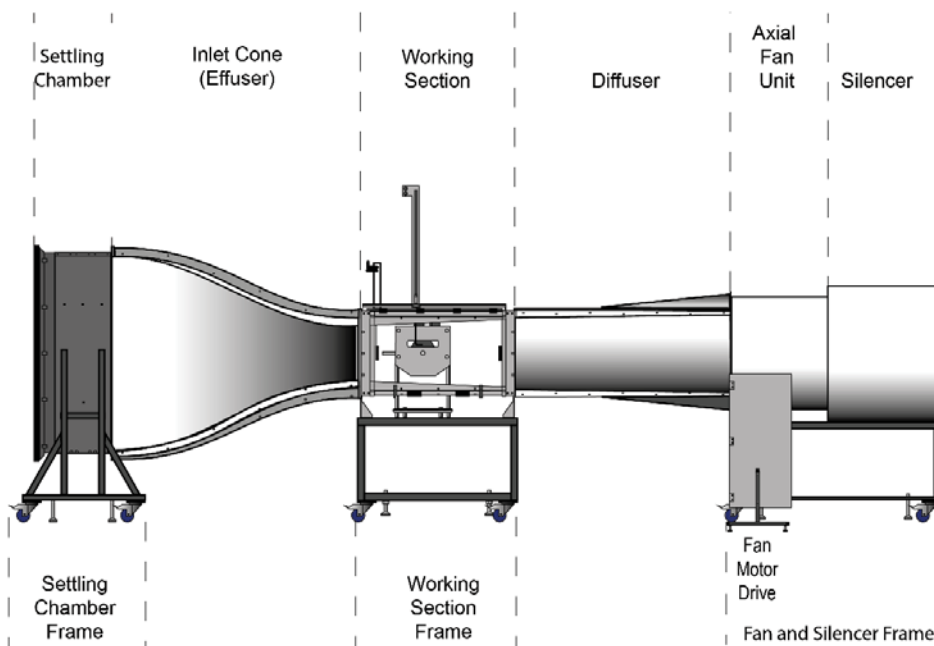

≡ SUBSONIC WIND TUNNEL 600 MM

VDAS® AF1600S

OPTIONAL MODELS

- Cylinder Model with Pressure Tapping (AF1600a) (included with AF1600s)
- 150 mm Chord NACA0012 Aerofoil with Tappings (AF1600B)
- 150 mm chord NACA2412 aerofoil with Variable Flap (AF1600C)
- 150 mm Chord NACA0012 Aerofoils (AF1600D) Flat Plate Boundary Layer Model Roughened and Smooth (AF1600f)
- Aircraft Model – Low Wing (AF1600g) and Aircraft Model – High Wing (AF1600h)
- Three-dimensional Drag Models (AF1600j)

INCLUDED ANCILLARIES

THREE-COMPONENT BALANCE (AF1600T)

The Three-Component Balance fits onto the working section of TecEquipment's Subsonic Wind Tunnel (AF1600).

The Three-Component Balance provides an easy-to-use support system for wind tunnel models. It measures lift, drag and pitching moment exerted on the model.

A mechanism constrains it to move in a plane parallel to the mounting plate only, while leaving it free to rotate about a horizontal axis. This arrangement provides the necessary three degrees of freedom.

Models used with the equipment will need a mounting stem. The forces acting on the model are transmitted by cables to three strain gauged load cells. The output from each load cell is taken via an amplifier to a microprocessor-controlled display module. The display module mounts onto the wind tunnel control and instrumentation frame and includes a digital display to show the lift, drag and pitching moment directly.

The equipment is fully compatible with TecEquipment's Versatile Data Acquisition System (VDAS®) and can quickly and conveniently connect to the frame-mounting interface unit (VDAS-F).

The model support of the balance can be rotated by 360 degrees. This allows adjustment of the angle of incidence of the model to the direction of air flow. The model support is locked in the required position by a simple clamp after adjustment.

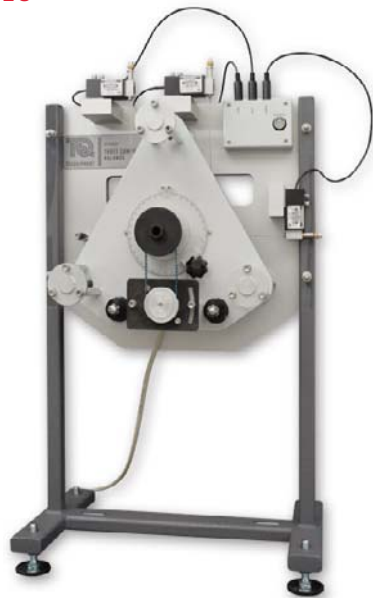

SHOWN FITTED WITH THE BALANCE ANGLE FEEDBACK UNIT (INCLUDED)

BALANCE ANGLE FEEDBACK UNIT (AFA4)

The Balance Angle Feedback Unit (included with AF1600t) is for use with the Three-Component Balance (see above) to measure the angular position of models mounted on the balance in the wind tunnel.

The Angle Feedback Unit mounts on the Three-Component Balance attached to the wind tunnel. It then transmits the rotational angle of the model to (VDAS®). The angle of the model is logged on a suitable computer along with the other captured experimental data. The Feedback Unit is supplied fitted to the Three-Component Balance.

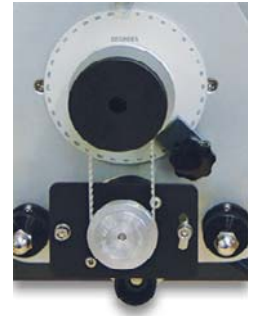

DUAL DIFFERENTIAL PRESSURE UNIT (DP6)

The Dual Differential Pressure Unit measures and displays pressures in Pitot-static tubes and other pressure-sensing devices fitted to the wind tunnel, with respect to the atmosphere or differential pressures.

It is microprocessor-controlled and contains calibrated pressure transducers. The unit has an integral liquid crystal display that allows the user to read pressures directly. The signals of the pressure sensors may be output to TecEquipment's Versatile Data Acquisition System (VDAS®).

When the Differential Pressure Transducer is used with the automatic data acquisition unit (VDAS®) it provides a significant advantage over conventional instruments such as manometers. Many readings can be taken and the user may use a suitable spreadsheet software package to obtain a more accurate overview of pressure distributions.



32-WAY PRESSURE DISPLAY UNIT (AFA6)

The 32-Way Pressure Display Unit measures and displays up to 32 different pressures from models, Pitot-static tubes and other measuring instruments fitted to the wind tunnel. It is ideally suited to applications where multiple pressure measurements are required, for example in boundary layer and tapped aerofoil model investigations.

The unit mounts onto the control and instrumentation frame of the AF1600 Wind Tunnel. The microprocessor-controlled unit contains 32 calibrated pressure transducers.



≡ SUBSONIC WIND TUNNEL 600 MM

VDAS® AF1600S

Input connection to each of the pressure transducers is via quick-release pressure inputs mounted on the front panel of the unit. This allows easy and quick connection between the unit and an experiment mounted in the wind tunnel. All pressures are measured with respect to atmosphere. The unit has an integral liquid crystal display with a scroll switch that allows all 32 channels to be viewed in groups of four at any time.

The conditioned outputs of the pressure sensors, may be output to VDAS®.

When the 32-Way Pressure Display Unit is used with the system it allows laboratory time to be used more efficiently because data can be captured and processed much more quickly than when using manual techniques. The facility in the software to average data to remove the fluctuations inherent in wind tunnel measurements, enhances the quality of the results making their interpretation much easier. This option provides significant experimental advantages over conventional instruments such as manometers.

PITOT-STATIC TRAVERSE (AFA7)



A Pitot-static tube that mounts in the working section of the wind tunnel, either upstream of the position of the test model or on the fore-aft traverse. This allows students to do 'wake' traverses, of a model. The vertical position of the tube, which is adjustable, is displayed on a digital indicator.

The digital indicator position can be set to zero in any position. This allows the datum or starting point of an experiment to be defined by the user.

To display differential pressure, the Pitot-static tube connects to the Tilting Multi-Tube Manometer (AFA1) (supplied as an optional extra).

Alternatively, pressures can be measured using one or more of the following (supplied) instruments:

- Differential Pressure Unit (DP6)
- 32-Way Pressure Display Unit (AFA6)

The position of the Pitot-static Traverse may be output to VDAS® to allow computer-based data acquisition and display.

PITOT-STATIC X/Y TRAVERSE (AF1600XY)



This is an X/Y traverse Pitot-static unit that fits to the top of the working section of the AF1600. It connects to VDAS® for the display of the Pitot-tube position (in both axes). The pressure tapping may be connected to AFA6, the 32-Way Pressure Display Unit (included) for electronic display and to link with VDAS®.

PROTRACTOR

The protractor fits on to the shaft of a model when the Three-Component Balance is not being used. It can be used when setting up models and rotating them during experiments.



CYLINDER MODEL WITH PRESSURE TAPPING (AF1600A)



A cylinder model that spans the full width of the working section of the Subsonic Wind Tunnel (AF1600s). A holder (included with the wind tunnel) supports the model in the tunnel. Also, the optional Three-Component Balance (AF1600t, available separately).

≡ SUBSONIC WIND TUNNEL 600 MM

VDAS® AF1600S

The model includes a single pressure tapping so, by rotating the model, students can find the pressure distribution around the cylinder. TecQuipment offers several suitable pressure-measuring instruments (available separately).

Using a Pitot tube, students can traverse the model wake to find the downstream pressure distribution and find the drag on the model. They can compare this to direct measurements, obtained using a balance.

TecQuipment's Smoke Generator (AFA11, not included) increases the educational value of the experiments by showing the flow of air around the model.

MODEL HOLDER

The model holder is supplied to hold a model if the Three-Component Balance is not used. It is designed to hold a shaft of diameter 11.95 ± 0.015 mm (diameter) and 215 ± 1.25 mm (length) mounting stem.



VERSATILE DATA ACQUISITION SYSTEM (VDAS-F)

The AF1600 is supplied with TecQuipment's modern, cost-effective and accurate Versatile Data Acquisition System (VDAS®) that improves laboratory teaching. It works with a growing list of over 50 TecQuipment products, enabling real-time display and capture of experiment data.

For both individual student use or for lecturers demonstrating experiments to a whole class, VDAS® gives real-time calculation, recording and charting with fast data export. This makes for efficient, productive and effective use of time for both students and lecturers.



VDAS® consists of hardware and software.

The digital inputs on the interface connect directly to the instrumentation on suitable TecQuipment products. These inputs are non-specific, for easy experiment setup and reduced connection errors. The mostly digital communications circuits make the equipment more resistant to electrical noise than purely analogue systems.

The interface units also have two analogue inputs. These are for fast-moving (transient) signals from some TecQuipment products or for transducers and sensors. These may include displacement or pressure measuring sensors and flow meters. VDAS® can display the analogue signals in real-time as traces on a computer screen. This allows VDAS® to work as a user-friendly alternative to an oscilloscope on selected products.

The output from the interface unit connects to a computer (not supplied) running the VDAS® software. The software has extra features that allow the addition of derivative traces and reference traces, based on each of the two analogue input signals. It is also possible to adjust software filtering and smoothing of each signal trace, and scale the traces to best fit the trace area.

The software is intuitive and easy to use, with clear and convenient data display options. The software looks similar and works in a similar way for each TecQuipment VDAS®-compliant product. This saves time as students do not have to learn to use new software when changing experiments.

VDAS® software features include:

- Recording data manually or automatically
- Data capture set by time or intervals
- Display of real-time data, in digital form or as an analogue meter
- Real-time traces of analogue signals
- Logging data for printing and later analysis
- Exporting data for use by other software
- Performing real-time calculations to generate user-defined data
- Creating and printing charts and data tables
- Customisable layouts

RECOMMENDED ANCILLARIES

MULTI-TUBE MANOMETER (OPTIONAL) (AFA1)



A 36-tube tilting manometer for measuring pressure in subsonic wind tunnels, including TecQuipment's AF1600. A backboard with a graduated scale holds each manometer tube.

For safety and convenience the manometer uses water as the manometer fluid. This is via an adjustable reservoir with a fine-adjust handwheel held at the side of the equipment. Water colouring is included to aid visibility.

The top of each manometer tube has a connection piece for tubing to connect to pressure tapings on the equipment being monitored. The whole manometer

≡ SUBSONIC WIND TUNNEL 600 MM

VDAS® AF1600S

tube assembly is mounted on a swivel. This allows it to be tilted in preset increments to increase the sensitivity of measurement. Adjustable feet enable the whole apparatus to be precisely levelled before use.

The manometer is supplied with operating instructions, a filling funnel and a spirit level.

SMOKE GENERATOR (OPTIONAL) (AFA11)



The smoke generator and probe is an optional ancillary to allow the observation of airflow in subsonic wind tunnels and other airflow situations.

LEARNING OUTCOMES

AF1600s is designed to be flexible and utilised for a variety of possible experiments designed by our customers.

Typical examples include:

- Flow past bluff and streamlined bodies with pressure and velocity observations in the wake
- Investigations into boundary layer development
- Influence of aspect ratio on aerofoil performance
- Pressure distribution around a cylinder under sub-critical flow conditions
- Study of characteristics of models involving basic measurement of lift and drag forces
- Study of the characteristics of three-dimensional aerofoils involving measurements of lift, drag and pitching moment
- Study of the pressure distribution around an aerofoil model to derive the lift, and comparison with direct measurements of lift
- Drag force on a bluff body normal to an air flow
- Flow visualisation

STANDARD FEATURES

- Supplied with comprehensive user guide
- Five-year warranty
- Manufactured in accordance with the latest European Union directives
- An ISO 9001 certified company

INCLUDED ANCILLARIES

- Three Component Balance (AF1600t)
- Balance Angle Feedback Unit (AFA4)
- Dual Differential Pressure Display (DP6)
- 32-Way Pressure Display Unit (AFA6)
- Pitot-Static Traverse (AFA7)
- Pitot-Static X/Y Traverse (AF1600xy)
- Protractor
- Model Holder
- Versatile Data Acquisition System (VDAS-F)
- Cylinder Model with Pressure Tapping (AF1600a)

RECOMMENDED ANCILLARIES

- Multi-Tube Manometer (AFA1)
- Smoke Generator (AFA11)

RECOMMENDED EXPERIMENTS

- 50 mm chord NACA0012 aerofoil with tappings (AF1600b)
- 50mm chord NACA2412 aerofoil with variable flap (AF1600c)
- 150 mm chord NACA0012 aerofoils (AF1600d)
- Flat Plate Boundary Layer Model roughened and smooth (AF1600f)
- Aircraft Model low wing (AF1600g)
- Aircraft Model high wing (AF1600h)
- Three-dimensional drag models (AF1600j)

ANCILLARY AND MODEL SPECIFICATIONS

For specifications of included and optional ancillaries and models please see their individual data sheets.

≡ SUBSONIC WIND TUNNEL 600 MM

VDAS® AF1600S

OPERATING CONDITIONS

ENVIRONMENT:

Laboratory

STORAGE TEMPERATURE RANGE:

-25°C to +55°C (when packed for transport)

OPERATING TEMPERATURE RANGE:

+5°C to +40°C

OPERATING RELATIVE HUMIDITY RANGE:

80% at temperatures < 31°C decreasing linearly to 50% at 40°C

WIND TUNNEL SPECIFICATIONS (AF1600)

TecQuipment is committed to a programme of continuous improvement; hence we reserve the right to alter the design and product specification without prior notice.

NETT DIMENSIONS AND WEIGHT

(ASSEMBLED, WITHOUT STAND ALONE ITEMS: ELECTRIC BOX, INSTRUMENT FRAME AND INSTRUMENTS):

7515 mm length x 1880 mm wide x 2240 mm height (2600 mm high with Pitot-static x/y traverse fitted), 1156 kg

WORKING SECTION:

600 mm x 600 mm x 1250 mm.

RECOMMENDED MINIMUM ROOM SIZE:

14 m x 6 m

AIR VELOCITY:

0 to 35 m.s⁻¹

ELECTRICAL SUPPLY (THREE PHASE):

Three phase with neutral, 380 – 440 VAC, 50 / 60 Hz, 40 A

III SUBSONIC WIND TUNNEL 600 MM

VDAS® AF1600S

PRODUCT SHIPS IN MULTIPLE COMPONENTS

Large component dimensions:

